



Technical Data

CONTURA™ SERIES RECESSED PAPER TOWEL DISPENSER

B-4362



Patented

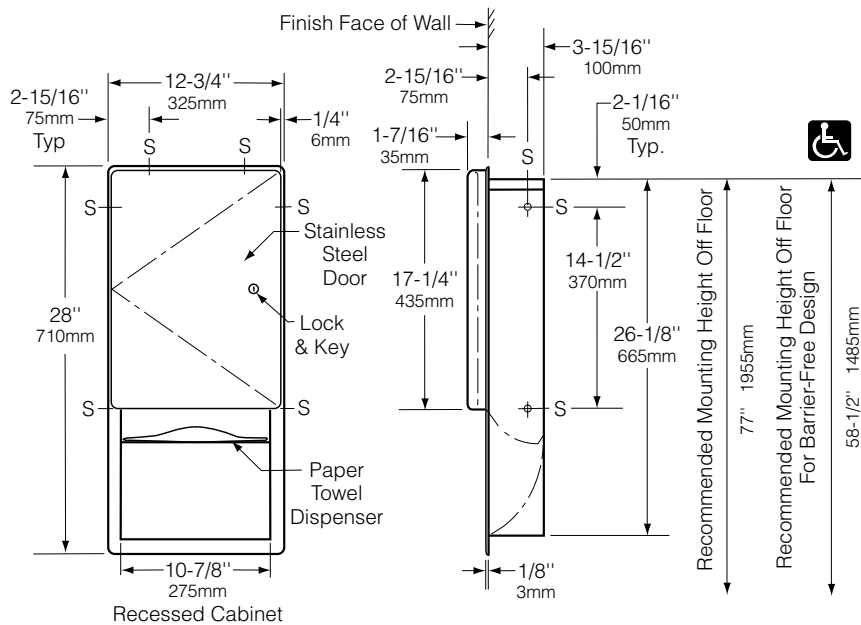

Rough Wall Opening
 11-3/8" (290mm) wide
 26-1/2" (675mm) high
 4" (102mm) minimum
 recessed depth

MATERIALS:

Cabinet — 18-8 S, type-304, 22-gauge (0.8mm) stainless steel. All-welded construction. Exposed surfaces have satin finish.

Flange — 18-8 S, type-304, 22-gauge (0.8mm) stainless steel with satin finish. Drawn, one-piece, seamless construction. Radius on corners and return edges complement corners and edges of door.

Door — 18-8 S, type-304, 18-gauge (1.2mm) stainless steel with satin finish. Drawn, one-piece, seamless construction. Front of door has same degree of arc as other Bobrick Contura Series washroom accessories. Radius on corners and edges of door complement other Contura Series accessories. Secured to cabinet with a full-length stainless steel piano-hinge. Equipped with a flush tumbler lock keyed like other Bobrick washroom accessories.

Paper Towel Dispenser — 18-8 S, type-304, 22-gauge (0.8mm) stainless steel with satin finish. Rounded towel tray has hemmed opening to dispense paper towels without tearing. Capacity: 600 C-fold or 800 multifold paper towels.

OPERATION:

Paper towel dispenser will dispense C-fold or multifold paper towels without adjustment or use of adapters.

INSTALLATION:

Provide framed rough wall opening 11-3/8" wide x 26-1/2" high (290 x 675mm). Minimum recessed depth required to finish face of wall is 4" (102mm). Allow clearance for construction features that may protrude into rough wall opening from opposite wall. Coordinate with mechanical engineer to avoid pipes, vents, and conduits in wall. If unit projects above top of wainscot, provide aluminum channel or other filler to eliminate gap between flange and finish face of wall. Mount unit in wall opening with shims between framing and cabinet at all points indicated by an S, then secure with screws furnished by manufacturer.

SPECIFICATION:

Recessed paper towel dispenser shall be type-304 stainless steel with all-welded construction; exposed surfaces shall have satin finish. Front of paper towel dispenser door shall have same degree of arc and match other Bobrick Contura™ Series accessories in the washroom. Radius on corners and edges of flange and door shall complement other Bobrick Contura™ Series washroom accessories. Flange shall be drawn, one-piece, seamless construction. Paper towel dispenser door shall be drawn, 18-gauge (1.2mm), one-piece, seamless construction; secured to cabinet with a full-length stainless steel piano-hinge; and equipped with a flush tumbler lock keyed like other Bobrick washroom accessories. Paper towel dispenser shall dispense 600 C-fold or 800 multifold paper towels. Manufacturer's service and parts manual shall be provided to the building owner/manager upon request.

Recessed Paper Towel Dispenser shall be Model B-4362 of Bobrick Washroom Equipment, Inc., Clifton Park, New York; Jackson, Tennessee; Los Angeles, California; Bobrick Washroom Equipment Company, Scarborough, Ontario; Bobrick Washroom Equipment Pty. Ltd., Australia; and Bobrick Washroom Equipment Limited, United Kingdom.