

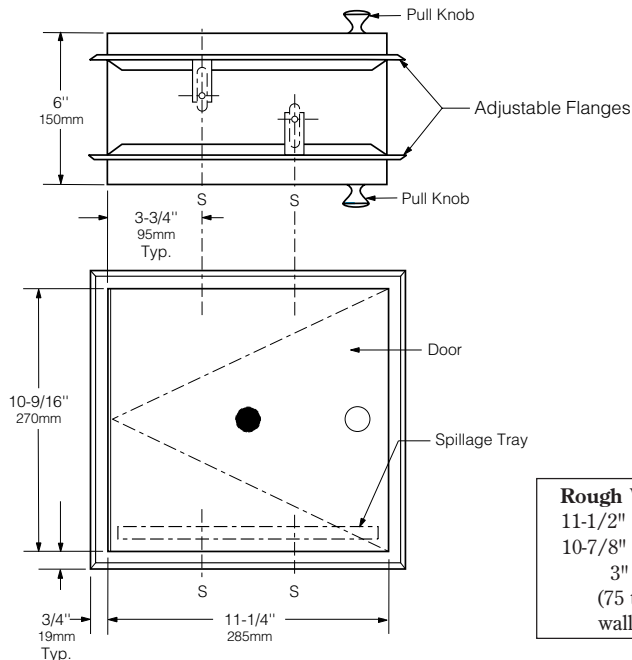

Technical Data

RECESSED SPECIMEN PASS-THROUGH CABINET

B-505



Rough Wall Opening
11-1/2" (290mm) wide
10-7/8" (275mm) high
3" to 5-3/4" (75 to 145mm) wall thickness

MATERIALS:

Cabinet — 18-8 S, type-304, 22-gauge (0.8mm) stainless steel. All-welded construction. Exposed surfaces have satin finish. Two slots located on top and bottom for mounting.

Flanges (2) — 18-8 S, type-304, 22-gauge (0.8mm) stainless steel with satin finish. Drawn and beveled, one-piece, seamless construction. One mounting tab with screw hole located on top and bottom.

Doors (2) — 18-8 S, type-304, 18-gauge (1.2mm) stainless steel with satin finish. Each door is spring-loaded and secured to cabinet with a full-length stainless steel piano-hinge. Doors equipped with cast-aluminum pull knob, interlocking mechanism, and international graphic symbol identifying specimen cabinet.

Spillage Tray — 18-8 S, type-304, 24-gauge (0.6mm) stainless steel. All-welded construction.

OPERATION:

Interlocking mechanism on self-closing doors prevent both doors from being open at the same time; provides sight-barrier for complete privacy. Spillage tray is easily removed for cleaning.

INSTALLATION:

Provide framed rough wall opening 11-1/2" wide x 10-7/8" high (290 x 275mm). Wall thickness may be from 3" to 5-3/4" (75 to 145mm). Allow clearance for construction features that may protrude into rough wall opening. Coordinate with mechanical engineer to avoid pipes, vents, and conduits. Slide one flange onto cabinet so that screw holes in mounting tabs are aligned with mounting holes in cabinet. Center cabinet in wall opening. Slide second flange into place, aligning tabs with mounting holes and making certain entire perimeter of both flanges are tight against wall surface. Open one door and secure unit with four #10 x 1/4" (4.8 x 6.4mm) mounting screws (not furnished) through cabinet mounting holes and flange tabs at points indicated by an S.

SPECIFICATION:

Specimen pass-thru cabinet shall be type-304 stainless steel with all-welded construction; exposed surfaces shall have satin finish. Flanges shall be drawn and beveled, one-piece, seamless construction. Spring-loaded doors shall be self-closing and secured to cabinet with a full-length stainless steel piano-hinge. Doors shall be equipped with interlocking mechanism to prevent both from being open at the same time, providing sight-barrier for complete privacy. International graphic symbol on doors shall identify specimen cabinet. Unit shall be furnished with a removable stainless steel spillage tray. Manufacturer's service and parts manual shall be provided to the building owner/manager upon completion of project.

Specimen Pass-Thru Cabinet shall be Model B-505 of Bobrick Washroom Equipment, Inc., Clifton Park, New York; Jackson, Tennessee; Los Angeles, California; Bobrick Washroom Equipment Company, Scarborough, Ontario; Bobrick Washroom Equipment Pty. Ltd., Australia; and Bobrick Washroom Equipment Limited, United Kingdom.